

DC rotary solenoid

6

Product group

G DA

Function

- Rotary movement without axial wave movement
- Rotation angle 35°, 65° and 95°
- Increasing torque characteristic (for smaller duty cycles almost linear torque characteristic)
- With and without return spring
- Clockwise and anti-clockwise

Construction

- Shaft protruding on both sides
- Spring return force infinitely adjustable
- Armature guided in ball bearings
- Fastening via thread bores at the end faces
- Insulation materials of the exciter coil correspond to thermal class B
- Electrical connection via free flexible lead ends
- Protection class according to DIN VDE / EN 60529 when it is properly installed: IP 20

Application examples

- Tooling machines, office machines, packing machines, textile machines
- Shutter for laser and optical devices
- Measuring and control technology

Options

- Proportional rotary solenoids, double-acting with high torque type GDR
- Reverse and polarized rotary solenoids on request
- Please contact us for application related solutions or functional units

Standards

- Design and testing according to VDE 0580
- Production according to ISO 9001



Fig. 1: G DA with return spring

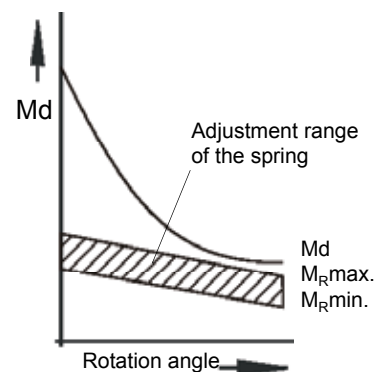

Fig. 2: torque characteristic and return spring characteristic

Technical data G DA X and G DA Y without spring return

G DA X ... X20 B01	025					035					050				
Rotation angle * (°)	95 ⁺³														
Operating mode rel. Einschaltdauer	S1 100 %	S3 40 %	S3 25 %	S3 15 %	S3 5 %	S1 100 %	S3 40 %	S3 25 %	S3 15 %	S3 5 %	S1 100 %	S3 40 %	S3 25 %	S3 15 %	S3 5 %
Torque M _d (Ncm) at Δ	0° 0,63	0,95	1,05	1,15	1,10	1,68	2,00	2,15	2,20	2,00	9,00	10,00	10,20	10,00	8,4
	30° 0,22	0,50	0,70	0,85	1,15	0,73	1,45	1,75	2,00	2,45	3,90	6,55	8,10	9,50	11,00
	60° 0,10	0,25	0,40	0,55	0,85	0,34	0,80	1,20	1,45	2,00	1,50	3,25	4,80	6,60	8,90
	95° 0,065	0,17	0,27	0,40	0,80	0,22	0,58	0,90	1,30	2,25	0,77	1,70	2,55	4,10	7,40
Rated power P ₂₀ (W)	4,2	10,9	16,6	24,3	57,6	7,0	16,2	24,2	38	105	13,3	27,2	41,5	75	168
Moment of inertia (kgm ²)	1,02 x 10 ⁻⁶					0,314 x 10 ⁻⁶					1,903 x 10 ⁻⁶				
Time constant τ (ms)	6					6,5					9,2				
Solenoid weight m _M (kg)	0,07					0,16					0,42				

G DA Y ... X20 B01	025					035					050				
Rotation angle * (°)	65 ⁺³														
Operating mode rel. Einschaltdauer	S1 100 %	S3 40 %	S3 25 %	S3 15 %	S3 5 %	S1 100 %	S3 40 %	S3 25 %	S3 15 %	S3 5 %	S1 100 %	S3 40 %	S3 25 %	S3 15 %	S3 5 %
Torque M _d (Ncm) at Δ	0° 0,98	1,50	1,65	1,80	1,80	2,40	2,90	3,00	3,00	3,00	13,9	15,3	15,7	15,7	14,3
	20° 0,46	1,00	1,30	1,55	1,85	1,5	2,35	2,75	3,10	3,60	8,8	12,9	14,6	15,8	17,1
	40° 0,25	0,60	0,85	1,15	1,60	0,85	1,70	2,10	2,50	3,25	4,3	7,9	10,5	12,9	15,6
	65° 0,16	0,40	0,60	0,85	1,50	0,57	1,26	1,80	2,50	3,60	2,4	5,0	7,2	10,0	14,4
Rated power P ₂₀ (W)	4,2	10,9	16,6	24,3	57,6	7,0	16,2	24,2	38	105	13,3	27,2	41,5	75	168
Moment of inertia (kgm ²)	1,15 x 10 ⁻⁶					0,366 x 10 ⁻⁶					2,04 x 10 ⁻⁶				
Time constant τ (ms)	9					8,0					15,5				
Solenoid weight m _M (kg)	0,07					0,16					0,42				

G DA Y... X20 B03	025					035					050				
Rotation angle * (°)	35 ⁺³														
Operating mode rel. Einschaltdauer	S1 100 %	S3 40 %	S3 25 %	S3 15 %	S3 5 %	S1 100 %	S3 40 %	S3 25 %	S3 15 %	S3 5 %	S1 100 %	S3 40 %	S3 25 %	S3 15 %	S3 5 %
Torque M _d (Ncm) at Δ	0° 1,05	1,60	1,90	2,00	2,10	2,50	3,3	3,6	3,9	4,3	14,4	17,7	19,2	20,0	20,4
	10° 0,84	1,55	1,90	2,15	2,55	2,10	3,10	3,50	3,95	4,60	12,3	16,2	18,0	19,8	21,8
	20° 0,66	1,35	1,80	2,20	2,90	1,80	2,90	3,50	4,10	5,20	10,0	15,4	18,0	20,7	24,3
	35° 0,38	0,90	1,30	1,70	2,60	1,20	2,40	3,00	3,70	5,10	5,9	10,6	13,6	16,9	21,7
Rated power P ₂₀ (W)	4,2	10,9	16,6	24,3	57,6	7,0	16,2	24,2	38	105	13,3	27,2	41,5	75	168
Moment of inertia (kgm ²)	1,40 x 10 ⁻⁶					0,358 x 10 ⁻⁶					2,11 x 10 ⁻⁶				
Time constant τ (ms)	9					12					20				
Solenoid weight m _M (kg)	0,07					0,16					0,42				

* Other rotation angles on request

Notes on the tables

Due to natural dispersion torque data may deviate by approx. ± 10 % from the table values and base on:

- Rated voltage 24 V / 5 %-100 % duty cycle
- 90 % of the rated voltage
- Normal operating temperature at 35° ambient temperature
- Mounting on heat-insulating base

Duty cycle (%)	100	40	25	15	5
Operating time (s)	dauernd	120	75	45	15

Rated power P20 applies for a coil temperature of 20 °C

0° is the end position in energized condition.

The torque data M_d (Ncm) do not consider any return spring. For types with return spring, self-aligning torques according to table „**Technical Data with return spring**“ are to be considered.

Rated voltage

Rated voltage is = 24 V. An adaptation of the exciter coil to a rated voltage less than = 120 V is possible on request.

The devices correspond to protection class III. Electrical equipment of protection class III may be only connected to low voltage systems (PELV, SELV)(IEC 60364-4-41). The design limit of the equipment is a rated voltage not higher than 120 V (EN 61140:2002) with DC. On request we are pleased to check to what extent the delivery of higher rated voltages is possible as special solutions by agreement.

Technical data G DA X and G DA Y without return spring

G DA X ... X20 B01	060					075					100					
Rotation angle * (°)	95 ⁺³					95 ⁺³					95 ⁺³					
Operating mode rel. Einschaltdauer	S1 100 %	S3 40 %	S3 25 %	S3 15 %	S3 5 %	S1 100 %	S3 40 %	S3 25 %	S3 15 %	S3 5 %	S1 100 %	S3 40 %	S3 25 %	S3 15 %	S3 5 %	
Torque M _d (Ncm) at Δ	0°	19,5	22,3	22,6	22,3	17,9	34,0	33,0	31,0	28,5	19,0	68,0	68,0	65,0	59,0	37,0
	30°	7,5	14,2	17,0	19,6	23,4	19,4	30,0	33,5	35,5	39,0	51,0	66,0	72,0	77,0	83,0
	60°	3,0	6,4	9,7	13,0	18,9	8,1	17,5	22,5	27,5	33,0	28,0	47,0	57,0	65,0	78,0
	95°	1,3	3,4	5,0	7,6	14,0	4,4	11,1	16,2	20,5	35,0	16,0	38,0	52,0	66,0	89,0
Rated power P ₂₀ (W)	16,8	40	61	96	262	23,5	55,0	82,0	124,0	303,0	32,0	78,0	123,0	195,0	514,0	
Moment of inertia (kgm ²)	4,88 x 10 ⁻⁶					14,45 x 10 ⁻⁶					51,2 x 10 ⁻⁶					
Time constant τ (ms)	18					25					50					
Solenoid weight m _M (kg)	0,74					1,48					3,4					

G DA Y ... X20 B01	060					075					100					
Rotation angle * (°)	65 ⁺³					65 ⁺³					65 ⁺³					
Operating mode rel. Einschaltdauer	S1 100 %	S3 40 %	S3 25 %	S3 15 %	S3 5 %	S1 100 %	S3 40 %	S3 25 %	S3 15 %	S3 5 %	S1 100 %	S3 40 %	S3 25 %	S3 15 %	S3 5 %	
Torque M _d (Ncm) at Δ	0°	28,5	33,0	34,0	34,0	31,0	48	50	49	47	39	93	97	97	91	67
	20°	15,0	25,4	29,1	31,9	35,7	37	48	53	55	58	82	102	109	113	117
	40°	7,9	16,8	21,6	26,0	34,6	19	37	44	48	57	56	86	99	108	119
	65°	3,9	9,3	13,4	18,4	29,3	11	25	35	42	59	37	73	97	113	136
Rated power P ₂₀ (W)	16,8	40	61	96	262	23,5	55	82	124	303	32	78	123	195	514	
Moment of inertia (kgm ²)	5,14 x 10 ⁻⁶					15,25 x 10 ⁻⁶					54,6 x 10 ⁻⁶					
Time constant τ (ms)	22,5					30					75					
Solenoid weight m _M (kg)	0,74					1,48					3,4					

G DA Y... X20 B03	060					075					100					
Rotation angle * (°)	35 ⁺³					35 ⁺³					35 ⁺³					
Operating mode rel. Einschaltdauer	S1 100 %	S3 40 %	S3 25 %	S3 15 %	S3 5 %	S1 100 %	S3 40 %	S3 25 %	S3 15 %	S3 5 %	S1 100 %	S3 40 %	S3 25 %	S3 15 %	S3 5 %	
Torque M _d (Ncm) at Δ	0°	31,0	38,0	41,0	43,0	46,0	60	67	68	69	64	127	136	137	135	121
	10°	25,0	35,5	39,5	43,0	49,0	54	66	71	73	75	119	140	147	150	149
	20°	18,5	32,0	38,0	43,0	53,0	47	65	73	79	88	118	152	165	176	191
	35°	10,8	21,5	28,0	34,5	46,0	30	51	63	70	87	81	136	156	172	195
Rated power P ₂₀ (W)	16,8	40	61	96	262	23,5	55	82	124	303	32	78	123	195	514	
Moment of inertia (kgm ²)	5,39 x 10 ⁻⁶					15,92 x 10 ⁻⁶					57,9 x 10 ⁻⁶					
Time constant τ (ms)	30					42,5					100					
Solenoid weight m _M (kg)	0,74					1,48					3,4					

* Other rotation angles on request

Return spring - Adjustment

The above table indicates the adjustment range of the spring return torque depending on the operating mode. (Diagram fig. 3)

The spring return torque is to be modified within the adjustment range by changing the tooth spaces and by turning the spring housing. For turning the spring housing, the fastening screws are to be loosened and tightened again.

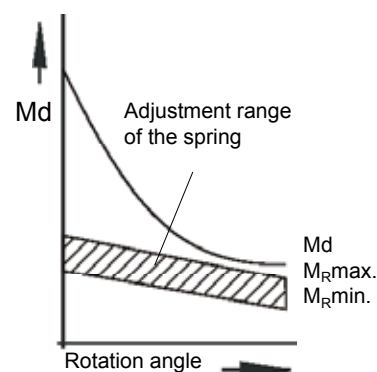

Fig. 4: torque characteristic and return spring characteristic

Technical data G DA X and G DA Y with return spring

Please note: Size 035 with operating mode S1 is not available with return spring.

G DA X ... X20 B21 B25	(clockwise) (anti-clockwise)	025					035					050							
		95 ⁺³					95 ⁺³					95 ⁺³							
Rotation angle *	(°)																		
Operating mode		S1	S3	S3	S3	S2	S1	S3	S3	S3	S2	S1	S3	S3	S3	S2			
		100 %	40 %	25 %	15 %	5 %	100 %	40 %	25 %	15 %	5 %	100 %	40 %	25 %	15 %	5 %			
Self-aligning torque of the spring M _R	(Ncm)	min.	–	0,1	0,1	0,1	0,1	0,1	–	0,14	0,14	0,14	0,14	0,14	0,3	0,3	0,3	0,3	0,3
		max.	–	0,1	0,2	0,3	0,5	–	0,18	0,34	0,74	0,74	0,74	0,3	0,6	1,25	2,4	3,0	
Spring constant	(Ncm/°)	0,00206					0,0065					0,016							

G DA Y ... X20 B21 B25	(clockwise) (anti-clockwise)	025					035					050					
		65 ⁺³					65 ⁺³					65 ⁺³					
Rotation angle *	(°)																
Operating mode		S1	S3	S3	S3	S2	S1	S3	S3	S3	S2	S1	S3	S3	S3	S2	
		100 %	40 %	25 %	15 %	5 %	100 %	40 %	25 %	15 %	5 %	100 %	40 %	25 %	15 %	5 %	
Self-aligning torque of the spring M _R	(Ncm)	min.	0,1	0,1	0,1	0,1	0,1	0,14	0,14	0,14	0,14	0,14	0,3	0,3	0,3	0,3	0,3
		max.	0,1	0,3	0,4	0,6	0,6	0,27	0,72	1,0	1,4	1,6	0,75	2,16	3,4	3,5	3,5
Spring constant	(Ncm/°)	0,00206					0,0065					0,016					

G DA Y ... X20 B23 B27	(clockwise) (anti-clockwise)	025					035					050				
		35 ⁺³					35 ⁺³					35 ⁺³				
Rotation angle *	(°)															
Operating mode		S1	S3	S3	S3	S2	S1	S3	S3	S3	S2	S1	S3	S3	S3	S2
		100 %	40 %	25 %	15 %	5 %	100 %	40 %	25 %	15 %	5 %	100 %	40 %	25 %	15 %	5 %
Self-aligning torque of the spring M _R	(Ncm)	min.	0,1	0,1	0,1	0,1	0,14	0,14	0,14	0,14	0,14	0,3	0,3	0,3	0,3	0,3
		max.	0,3	0,6	0,6	0,6	0,68	1,6	1,8	1,8	1,8	2,4	4	4	4	4
Spring constant	(Ncm/°)	0,00206					0,0065					0,016				

G DA X ... X20 B21 B25	(clockwise) (anti-clockwise)	060					075					100				
		95 ⁺³					95 ⁺³					95 ⁺³				
Rotation angle *	(°)															
Operating mode		S1	S3	S3	S3	S2	S1	S3	S3	S3	S2	S1	S3	S3	S3	S2
		100 %	40 %	25 %	15 %	5 %	100 %	40 %	25 %	15 %	5 %	100 %	40 %	25 %	15 %	5 %
Self-aligning torque of the spring M _R	(Ncm)	min.	0,56	0,56	0,56	0,56	0,56	1,1	1,1	1,1	1,1	1,1	2	2	2	2
		max.	0,6	1,0	2,0	4,0	5,6	1,8	5,0	8,4	11	11	12,5	20	20	20
Spring constant	(Ncm/°)	0,026					0,05					0,1				

G DA Y ... X20 B21 B25	(clockwise) (anti-clockwise)	060					075					100				
		65 ⁺³					65 ⁺³					65 ⁺³				
Rotation angle *	(°)															
Operating mode		S1	S3	S3	S3	S2	S1	S3	S3	S3	S2	S1	S3	S3	S3	S2
		100 %	40 %	25 %	15 %	5 %	100 %	40 %	25 %	15 %	5 %	100 %	40 %	25 %	15 %	5 %
Self-aligning torque of the spring M _R	(Ncm)	min.	0,56	0,56	0,56	0,56	0,56	1,1	1,1	1,1	1,1	1,1	2	2	2	2
		max.	1,5	4,0	6,2	6,5	6,5	4,65	11,7	12,5	12,5	12,5	22,5	22,5	22,5	22,5
Spring constant	(Ncm/°)	0,026					0,05					0,1				

G DA Y ... X20 B23 B27	(clockwise) (anti-clockwise)	060					075					100				
		35 ⁺³					35 ⁺³					35 ⁺³				
Rotation angle *	(°)															
Operating mode		S1	S3	S3	S3	S2	S1	S3	S3	S3	S2	S1	S3	S3	S3	S2
		100 %	40 %	25 %	15 %	5 %	100 %	40 %	25 %	15 %	5 %	100 %	40 %	25 %	15 %	5 %
Self-aligning torque of the spring M _R	(Ncm)	min.	0,56	0,56	0,56	0,56	0,56	1,1	1,1	1,1	1,1	1,1	2	2	2	2
		max.	4,8	7	7	7	7	14	14	14	14	14	25	25	25	25
Spring constant	(Ncm/°)	0,026					0,05					0,1				

* Other rotation angles on request

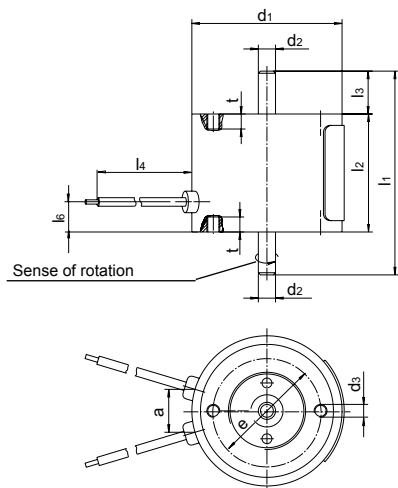

Fig. 5: Type G DA X 035 to 050 and G DA Y 035 to 050 (fastening holes: 2 x 180°)

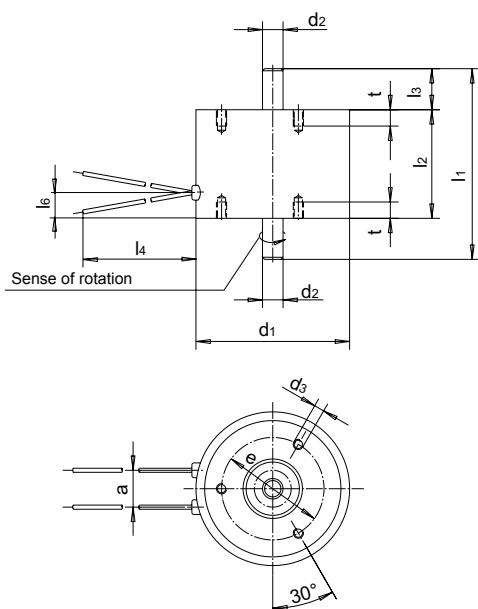

Fig. 6: Type G DA X 060 to 100 and G DA Y 060 to 100 (fastening holes: 3 x 120°)

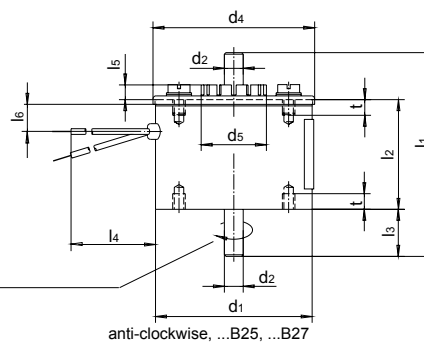
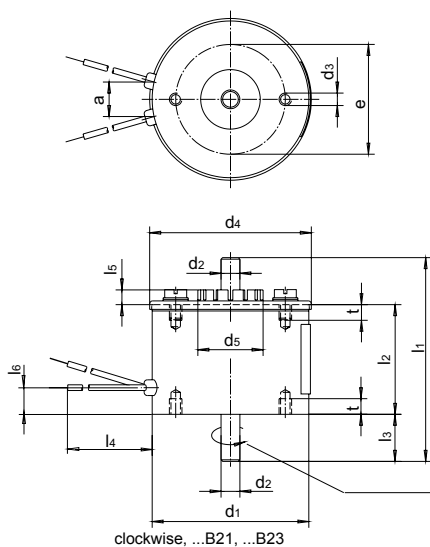

Fig. 7: Type G DA X 035 to 100 and G DA Y 035 to 100 (with return spring)

G DA X and G DA Y						
Size	025	035	050	060	075	100
Dim.	Dimensions in mm					
a	---	10	11	11	18	17
d ₁	25	35	50	60	75	100
d ₂	3	4	6	8	10	12
d ₃	M3	M3	M4	M4	M5	M6
d ₄	26,2	36,4	51,6	61,6	76,2	102
d ₅	11,4	14,6	20,8	24	29,5	32
e	18	25	35	40	50	70
l ₁	55	47,5	65	78	93	118
l ₂	25	27,5	35	42	53	68
l ₃	15	10	15	18	20	25
l ₄	100	100	150	150	200	260
l ₅	3,2	4,5	4,7	6	8,5	10
l ₆	5,5	7	8,5	10	12,5	16
t	3	3,5	5	6	8	9

We ask you to please do not exceed the screw depth, this could lead to damage of the coil.
The position of the shaft flattening (support of the return spring) to the fastening threads is variable.

Safety

Please make sure that the described devices are suitable for your application. Supplementary information concerning its proper installation can be taken also from the Technical Explanations, the effective DIN VDE0580 as well as the relevant specifications.

Installation instructions

The rotary solenoids may be inserted in any mounting position. In the interest of service life and function of the bearing, please make sure that impacts and bigger pressures on the rotation axis in axial direction are avoided.

In case of vertical installation, the support of installed masses should take place outside the solenoid. Furthermore it is advisable to do not intercept bigger, with the axis connected masses with the stops inside the solenoid but by external stops or damping elements installed by the customer.

The device may not show any mechanical or electrical damages. For application with reduced rotation angle the range from end position 0° (energized condition) should be used in order to achieve the max. possible torque.

Standard devices will be delivered with free lead ends. Types with clamps or connector on request.

For connection via plug connector Z KB X resp. Z KB G please pay attention to max. continuous current of the connector.

Type code

Example	G D A X	050	X20	B21
Type	G D A X: 95° G D A Y: 65°, 35°			
Size		025 035 050 060 075 100		
Code for execution & protection class			X20	
Numbering				Rotation angle 95° (GDAX) B01 without spring B21 with return spring clockwise B25 with return spring anti-clockwise Rotation angle 65° (GDAY) B01 without spring B21 with return spring clockwise B25 with return spring anti-clockwise Rotation angle 35° (GDAY) B03 without spring B23 with return spring clockwise B27 with return spring anti-clockwise

Order Example

Type G D A X 060 X20 B01
 Voltage == 24 V DC
 Operating mode S1 (100 %)

Information and remarks concerning European directives can be taken from the correspondent information sheet which is available under *Produktinfo.Magnet-Schultz.com*.

Note on the RoHS Directive

According to our current state of knowledge the devices pictured in this document do not contain any substances in concentration values or applications for which putting into circulation with products manufactured from them is prohibited in accordance to RoHS.

Please make sure that the described devices are suitable for your application. Supplementary information concerning its proper installation can be taken also from the  -Technical Explanation, the effective DIN VDE0580 as well as the relevant specifications.

This part list is a document for technically qualified personnel. The present publication is for informational purposes only and shall not be construed as mandatory illustration of the products unless otherwise confirmed expressively.

Specials designs

Please do not hesitate to ask us for application-oriented problem solutions. In order to find rapidly a reliable solution we need complete details about your application conditions. The details should be specified as precisely as possible in accordance with the relevant  -Technical Explanations.

If necessary, please request the support of our corresponding technical office.