

DC rotary solenoid

6

Product group

G DC

Function

- Rotation angle 95°
- Increasing torque characteristic (for smaller duty cycles linear up to slightly increasing torque characteristic)
- With and without return spring
- Clockwise and anti-clockwise

Construction

- Shaft protruding on both sides
- Spring return force infinitely adjustable
- Armature guided in ball bearings
- Fastening via thread bores at the end faces
- Insulation materials of the exciter coil correspond to thermal class B
- Electrical connection via free flexible lead ends
- Protection class according to DIN VDE / EN 60529 when it is properly installed: IP 20

Application examples

- Tooling machines, office machines, packing machines, textile machines
- Shutter for laser and optical devices
- Measuring and control technology

Options

- Proportional rotary solenoids, double-acting with high torque type GDR
- Reverse and polarized rotary solenoids on request
- Please contact us for application related solutions or functional units

Standards

- Design and testing according to VDE 0580
- Production according to ISO 9001



Fig. 1: Type G DC X 050 X20 A25

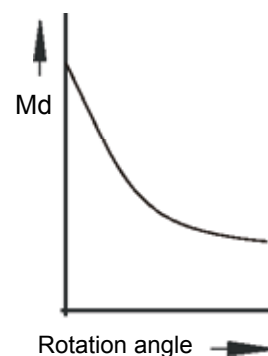


Fig. 2: torque characteristic

Technical data of the series G DC X

G DC X ... X20 A01	035					050					075					100				
Rotation angle * (°)	95 ⁺³					95 ⁺³					95 ⁺³					95 ⁺³				
Operating mode rel. Einschaltdauer	S1 100%	S3 40%	S3 25%	S3 15	S3 5%	S1 100%	S3 40%	S3 25%	S3 15%	S3 5%	S1 100%	S3 40%	S3 25%	S3 15%	S3 5%	S1 100%	S3 40%	S3 25%	S3 15%	S3 5%
Torque M _d (Ncm) at Δ	0° 2,20	3,40	3,50	3,65	3,40	12,2	13,0	13,0	13,0	10,0	44,0	43,0	40	36	26	76	66	59	42	34
	30° 1,00	2,25	3,00	3,50	3,25	6,5	10,0	11,5	13,1	10,2	29,0	40,0	43	46	35	74	85	93	93	65
	60° 0,50	1,20	1,85	2,55	3,25	2,5	5,3	7,4	9,3	10,4	12,0	25,0	29	35	40	49	70	78	85	89
	95° 0,38	0,94	1,55	2,40	3,75	1,6	3,4	5,0	7,0	15,4	6,7	15,5	21	29	44	32	64	79	89	114
Rated power P ₂₀ (W)	9,7	22,2	35,1	55	103	13,7	28,4	44,7	75	202	31	73	102	152	414	50,5	122	188	290	774
Moment of inertia (kgm ²)	7,6 x 10 ⁻⁷					4,28 x 10 ⁻⁶					2,62 x 10 ⁻⁵					1,074 x 10 ⁻⁴				
Time constant τ (ms)	9					18					60					90				
Solenoid weight m _M (kg)	0,22					0,55					2,0					4,5				

Notes on the tables

Due to natural dispersion torque data may deviate by approx. ± 10 % from the table values and base on:

- Rated voltage 24 V / 5 %-100 % duty cycle
- 90 % of the rated voltage
- Normal operating temperature at 35° ambient temperature
- Mounting on heat-insulating base

Duty cycle (%)	100	40	25	15	5
Operating time (s)	dauernd	120	75	45	15

Rated power P₂₀ applies for a coil temperature of 20 °C

0° is the end position in energized condition.

The torque data M_d (Ncm) do not consider any return spring. For types with return spring, self-aligning torques according to table „**Technical Data with return spring**“ are to be considered.

Rated voltage

Rated voltage is = 24 V. An adaptation of the exciter coil to a rated voltage less than = 120 V is possible on request.

The devices correspond to protection class III. Electrical equipment of protection class III may be only connected to low voltage systems (PELV, SELV)(IEC 60364-4-41). The design limit of the equipment is a rated voltage not higher than 120 V (EN 61140:2002) with DC. On request we are pleased to check to what extent the delivery of higher rated voltages is possible as special solutions by agreement.

Technical data G DC X with return spring

G DC X ... X20 A21 (clockwise) A25 (anti-clockwise)	035					050					075					100				
Rotation angle * (°)	95 ⁺³					95 ⁺³					95 ⁺³					95 ⁺³				
Operating mode rel. Einschaltdauer	S1 100%	S3 40%	S3 25%	S3 15	S3 5%	S1 100%	S3 40%	S3 25%	S3 15%	S3 5%	S1 100%	S3 40%	S3 25%	S3 15%	S3 5%	S1 100%	S3 40%	S3 25%	S3 15%	S3 5%
Spring return torque M _R (Ncm) min.	0,14	0,14	0,14	0,14	0,14	0,3	0,3	0,3	0,3	0,3	1,1	1,1	1,1	1,1	1,1	2	2	2	2	2
max.	0,16	0,6	0,9	1,4	1,4	1,2	2,8	3	3	3	4,4	10	11	11	11	17	20	20	20	20
Spring rate (Ncm/°)	0,0065					0,0,16					0,05					0,1				

Return spring - Adjustment

The above table indicates the adjustment range of the spring return torque depending on the operating mode. (Diagram fig. 3)

The spring return torque is to be modified within the adjustment range by changing the tooth spaces and by turning the spring housing. For turning the spring housing, the fastening screws are to be loosened and tightened again.

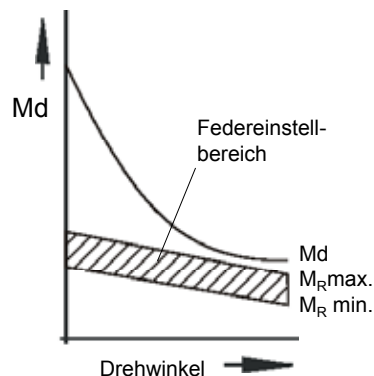


Bild 3: Drehmoment-Kennlinie und Rückstellfeder-Kennlinie

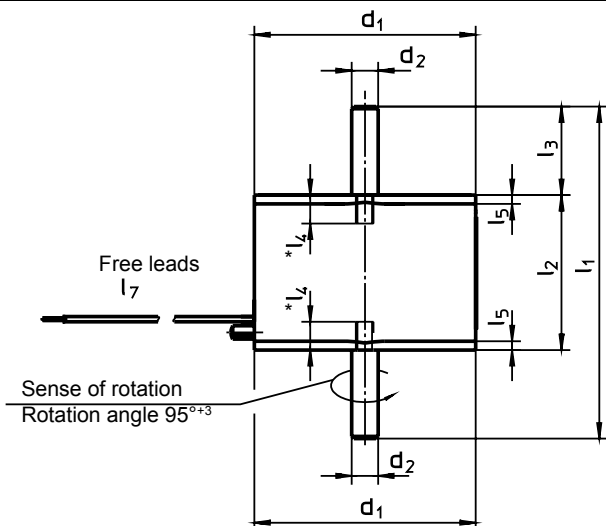


Fig. 4: G DC X 035 X20 A01 and
G DC X 050 X20 A01
(2 fastening holes)

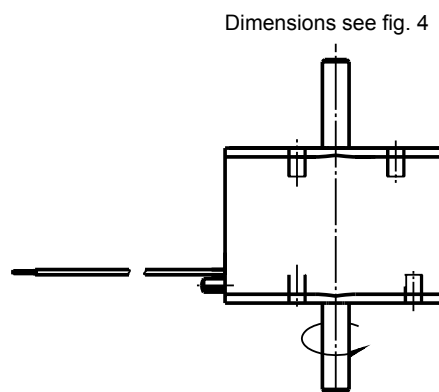
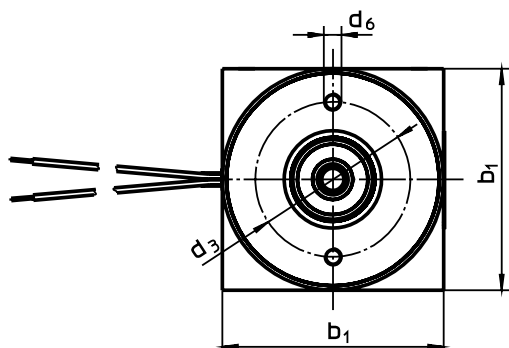


Fig. 5: G DC X 075 X20 A01 and
G DC X 100 X20 A01
(3 fastening holes)

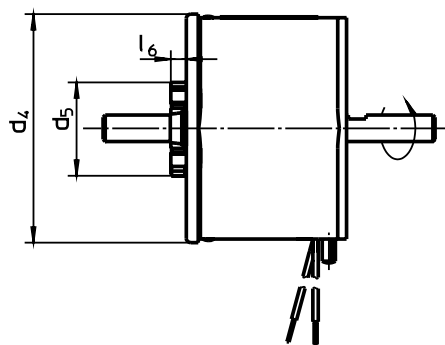
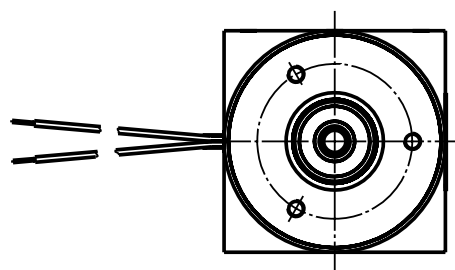


Fig. 6: G DC X ... X20 A21
(with return spring, clockwise)
All other dimensions see fig. 4

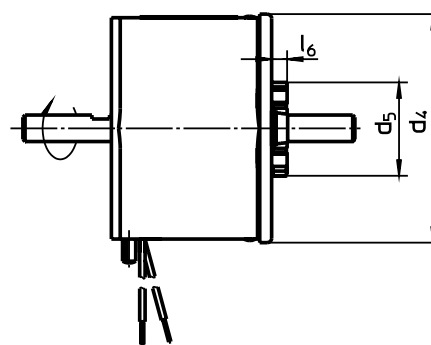


Fig. 7: G DC X ... X20 A25
(with return spring, anti-clockwise)
All other dimensions see fig. 4

Dimensions in mm	b ₁	d ₁	d ₂	d ₃	d ₄	d ₅	d ₆	l ₁	l ₂	l ₃	¹⁾ l ₄	l ₅	l ₆	l ₇	
G DC X	035	35	35 _{h11}	4 _{h8}	25	36,4	14,6	M3	57,5	27,5	15	3,5	1,8 _{0,1}	4,5	100
	050	50	50 _{h11}	6 _{h8}	35	51,6	20,8	M4	75	35	20	5	2 _{0,1}	4,7	150
	075	75	75 _{h11}	10 _{h8}	50	76,2	29,5	M5	103	53	25	8	2,5 _{0,1}	8,5	200
	100	100	100 _{h11}	12 _{h8}	70	102	32	M6	128	68	30	9	2,5 _{0,1}	10	260

Further sizes on request

¹⁾ We ask you to please do not exceed the screw depth l₄, because this could lead to damage of the coil.

Safety

Please make sure that the described devices are suitable for your application. Supplementary information concerning its proper installation can be taken also from the Technical Explanations, the effective DIN VDE0580 as well as the relevant specifications.

Installation instructions

The rotary solenoids may be inserted in any mounting position. In the interest of service life and function of the bearing, please make sure that impacts and bigger pressures on the rotation axis in axial direction are avoided.

In case of vertical installation, the support of installed masses should take place outside the solenoid. Furthermore it is advisable to do not intercept bigger, with the axis connected masses with the stops inside the solenoid but by external stops or damping elements installed by the customer.

The device may not show any mechanical or electrical damages. For application with reduced rotation angle the range from end position 0° (energized condition) should be used in order to achieve the max. possible torque.

Standard devices will be delivered with free lead ends. Types with clamps or connector on request.

For connection via plug connector Z KB X resp. Z KB G please pay attention to max. continuous current of the connector.

Type code

Example	G DC X	050	X20	A01
Type	G DC X:			
Size		035 050 075 100		
Code for execution & protection class			X20	
Numbering				


Rotation angle 95°

- A01** without spring
- A21** with return spring clockwise
- A25** with return spring anti-clockwise

Order example

Type G DC X 035 X20 A01
Voltage ≡ 24 V DC
Operating mode S1 (100 %)

Specials designs


Please do not hesitate to ask us for application-oriented problem solutions. In order to find rapidly a reliable solution we need complete details about your application conditions. The details should be specified as precisely as possible in accordance with the relevant -Technical Explanations.

If necessary, please request the support of our corresponding technical office.

Information and remarks concerning European directives can be taken from the correspondent information sheet which is available under *Produktinfo.Magnet-Schultz.com*.

Note on the RoHS Directive

According to our current state of knowledge the devices pictured in this document do not contain any substances in concentration values or applications for which putting into circulation with products manufactured from them is prohibited in accordance to RoHS.

Please make sure that the described devices are suitable for your application. Supplementary information concerning its proper installation can be taken also from the -Technical Explanation, the effective DIN VDE0580 as well as the relevant specifications.

This part list is a document for technically qualified personnel. The present publication is for informational purposes only and shall not be construed as mandatory illustration of the products unless otherwise confirmed expressively.