

Control Solenoid for Hydraulic ATEX + IECEX

4



Product group

G HP E

Function

- Armature space pressure tight, rated pressure 250 bar
- Increasing magnetic force vs. stroke characteristic
- Short correction times
- Push type

Construction

- Fastening via central thread
- Easy exchange of the magnetic body without opening the hydraulic circuit
- Insulation material of the exciter coil corresponds to insulation class H
- Elektrical connection via connecting cable
FL4G11Y 2x1,5mm²
- Protection class according to DIN 40050-9 when they are properly installed: IP69K
- Explosion protection:  II 2G Ex mb IIC T4 Gb
 II 2D Ex mb IIIC T130°C Db

Application examples

- Particularly used as proportional actuator in hydraulic open-loop control systems and control circuits in potentially explosive areas and in the presence of combustible dust (zones 1, 21)

Options and accessories

- Three wire connecting cable
- Other temperature classes
- Modifications and special designs
- Please contact us for application related problem solutions

Standards and approvals

- Design and testing according to VDE 0580
- Production according to ISO 9001
- ATEX, IECEX



Fig. 1: G HP E 037 AGD A01

Technical data

G HP E 037 A GD A01			
Operating mode		S1 (100 %)	
Reference temperature ϑ_{11}	(°C)	50	
Rated voltage U	(V)	24	
Total stroke s	(mm)	Magnetic force F_M (N)	
	0	75	
	0,5	55	
	1	51	
	1,5	52	
	2	41	
	2,5	22	
	3	14	
	3,5	9	
	4	7	
Working stroke s_W	(mm)	1,5	
Rated work W_N at working stroke s_W	(Ncm)	7,6	
Rated power P_{20}	(W)	17,3	
Operating frequency	(1/h)	3.600	
Armature weight m_A	(kg)	0,045	
Solenoid weight m_M	(kg)	0,41	
The temperature rise test is based on the mounting on an hydraulic slide with base plate having the minimum dimensions:	hydraulic slide	(mm)	46 x 46 x 66
	base plate	(mm)	66 x 46 x 30
	material	iron or material with the same or better heat conduction	

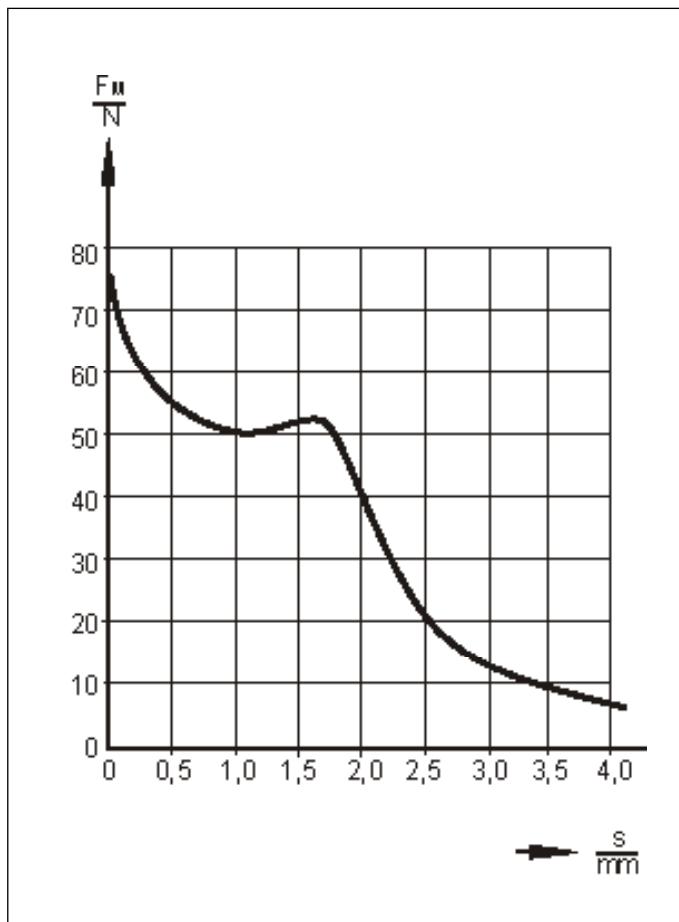

Fig. 2: Magnetic force vs. stroke characteristic G HP E 037 A GD A01

The devices correspond to protection class III. Electrical equipment of protection class III may be only connected to low voltage systems (PELV, SELV)(IEC 60364-4-41). The design limit of the equipment is a rated voltage not higher than 120 V (EN 61140:2002) with DC. On request we are pleased to check to what extent the delivery of higher rated voltages is possible as special solutions by agreement.

It has to be ensured by suitable measures that the specified limit values, particularly the range of control current, won't be exceeded.

An adaptation of the exciter coil to other current and resistance values is possible on request.

Due to natural dispersion the magnetic force values may deviate by $\pm 5\%$ from the values indicated in the tables.

Ventilation of the armature space and adjustment of the armature rod is possible on request.

Mechanical modifications in flange connection are possible on request.

The interior space of the solenoid and the bearing of the armature is resistant to all neutral fluids commonly used in hydraulic applications.

Please contact us, if other operating media are used.

Information and remarks concerning European directives can be taken from the correspondent information sheet which is available under Produktinfo.Magnet-Schultz.com.

Note on the RoHS Directive

The devices presented in this document do not fall into the scope of RoHS Directive and to our knowledge they do not become part of products which fall into this scope. In case of surfaces zinc coating with yellow chromating and zinc iron with black chromating separate agreements are necessary for applications within the scope of RoHS.

Please note the respective operating manual delivered with each device. An EC conformity declaration of the manufacturer is attached to every delivery one time.

Please make sure that the described devices are suitable for your application. Supplementary information concerning its proper installation can be taken also from the  -Technical Explanation, the effective DIN VDE0580 as well as the relevant specifications.

This part list is a document for technically qualified personnel.

The present publication is for informational purposes only and shall not be construed as mandatory illustration of the products unless otherwise confirmed expressively.

Magnetic body (dimensions for information purposes)

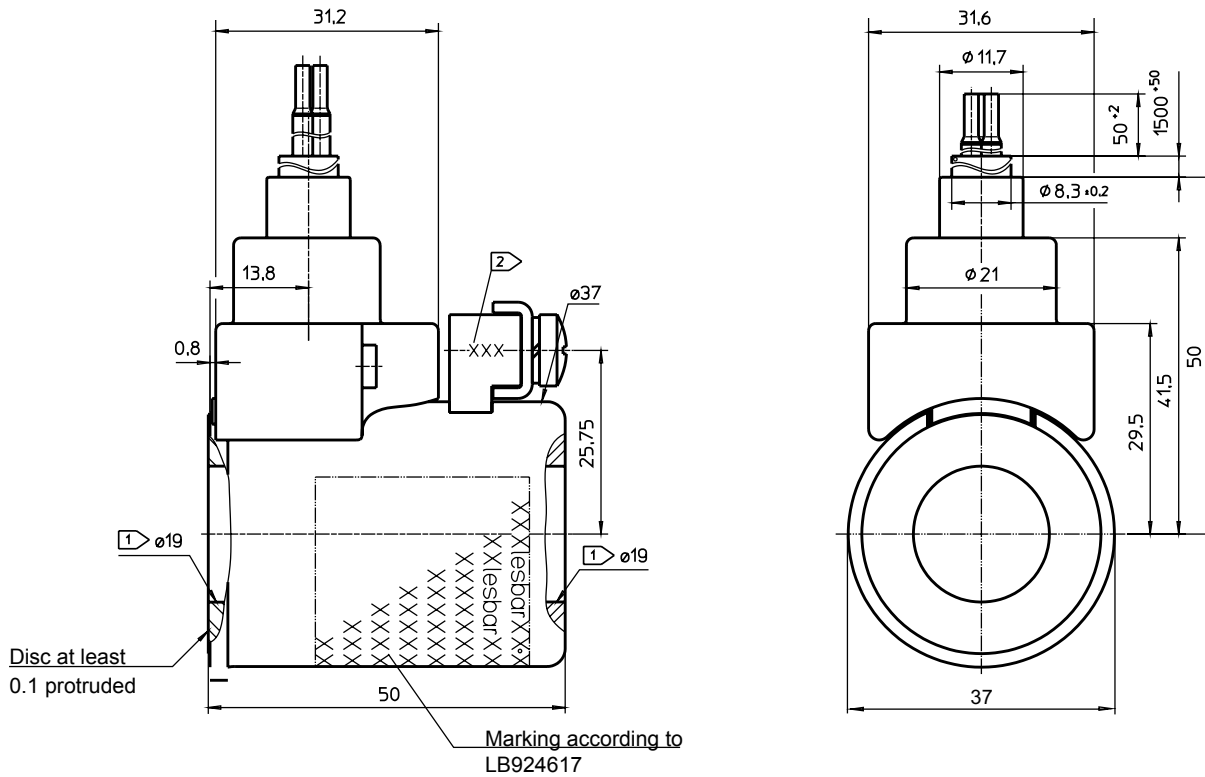

Fig. 3: Magnetic body 924617 (FHMSE037924617)

Tube (dimension for information purposes)

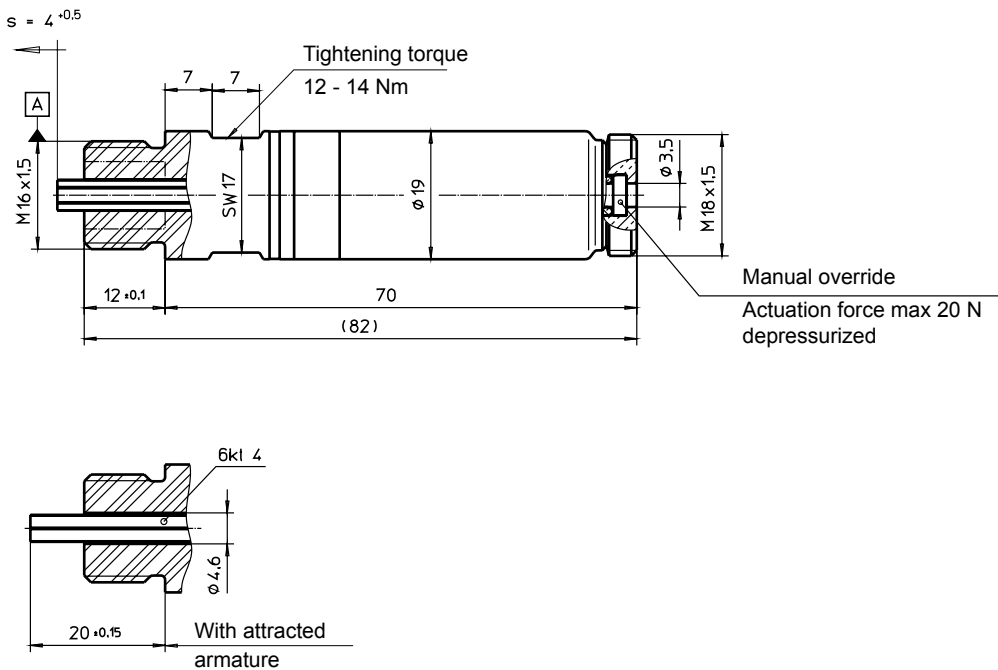

Fig. 4: Tube 923692 (FHTP037923692)

Complete proportional solenoid

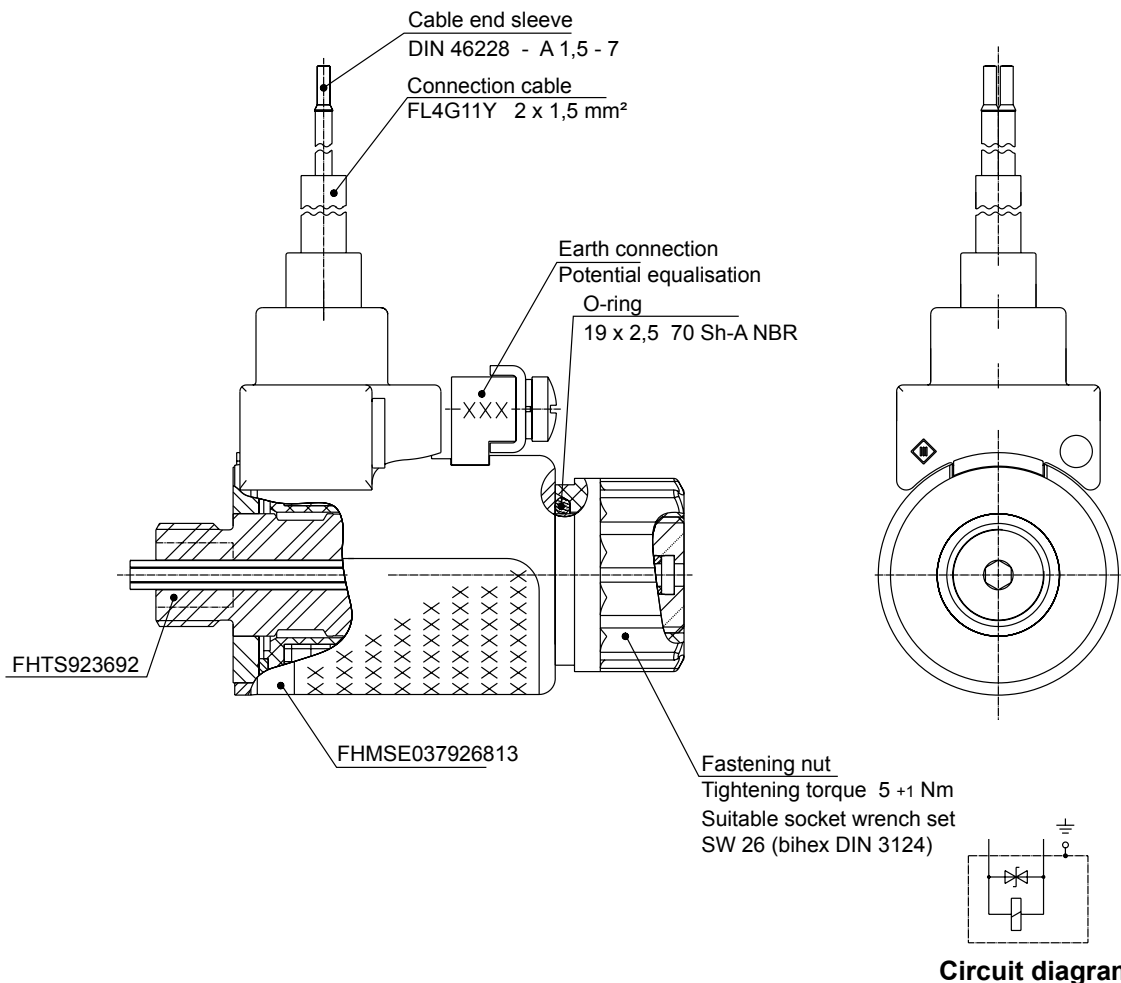

Fig. 5: Proportional solenoid G HP E 037 A GD A01

Fastening nut

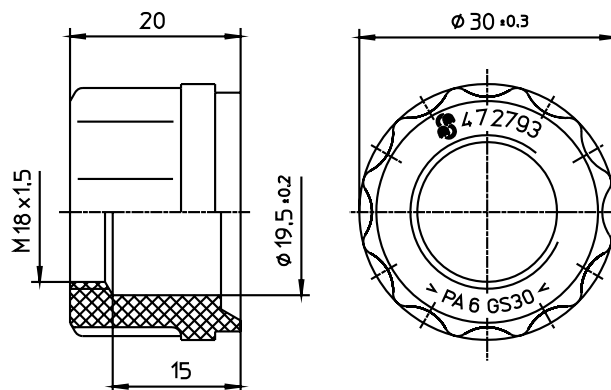
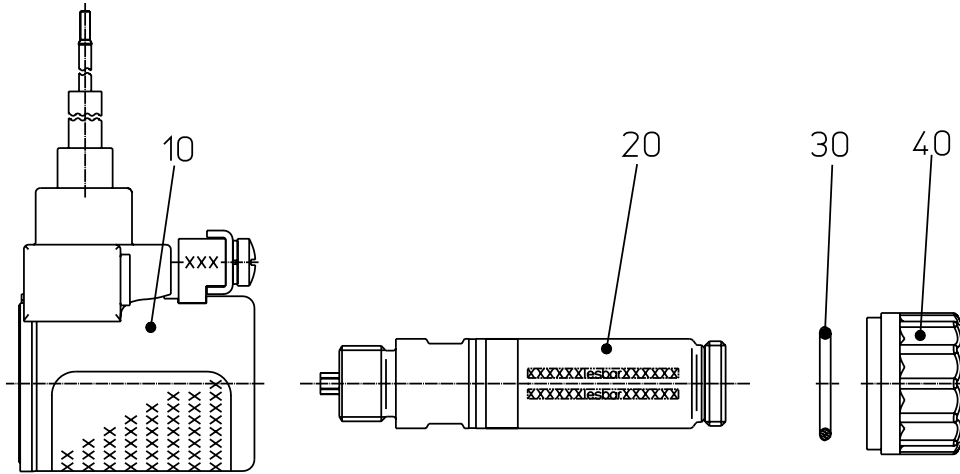

Fig. 6: Fastening nut 472793
 Suitable socket wrench SW26 (12 bihex DIN 3124)
 O-ring to be used: 19 x 2,5 70 shore A
 Tightening torque 5 +1 Nm

Single components



Item	Qty.	Designation	Part number
1	1	Magnetic body for 24 VDC	FHMSE924617-001
2	1	Tube	FHTS037923692
3	1	O-ring 19 x 2.5 70 Sh-A NBR	781754
4	1	Fastening nut	472793

Only available as complete device!

Order example

Type G HP E 037 AGD A01
Voltage == 24 V DC
Operating mode S1 (100 %)

Specials designs

Please do not hesitate to ask us for application-oriented problem solutions. In order to find rapidly a reliable solution we need complete details about your application conditions. The details should be specified as precisely as possible in accordance with the relevant -Technical Explanations.

If necessary, please request the support of our corresponding technical office.